



## PRODUCT SPECIFICATION

# LOW PRESSURE TRANSMITTER/CONTROLLER MODEL 222

### General Description

The Low Pressure Transmitter provides an accurate and reliable means of measuring and controlling low positive, negative and differential pressure.

The model 222 designed to measure pressure conditions within combustion plant can be used to control air flow for optimum combustion efficiency.

Specifically designed for boiler, incinerator and furnace applications, equally suitable for any inert gas heating and ventilating applications, or energy management systems.

Housed in a weatherproof aluminium enclosure to IP 65, the Model 222 incorporates a robust stainless steel variable capacitance sensor with quality solid state circuits providing accuracy and stability. The unit complies with current EMC and LUD standards.

The Transmitter is available with pressure ranges of  $\pm 0 - 5$  mm wg (0 to 0.5 mbar) to  $\pm 0 - 1000$  mm wg (0 to 100 mbar).

The Model 222 Transmitter will provide an analogue out-put signal of 0-10vDC or 0-1 mA or 4-20 mA switch selectable.

The Model 222 Transmitter/Controller will, in addition to transmitting an electrical signal proportional to pressure, provide a control or alarm function with the capability of operating an AC motor or damper actuator within the voltage range of 12 – 240v AC.

The control function utilises solid state relays and a selectable control filter to provide a time averaging proportional control facility.

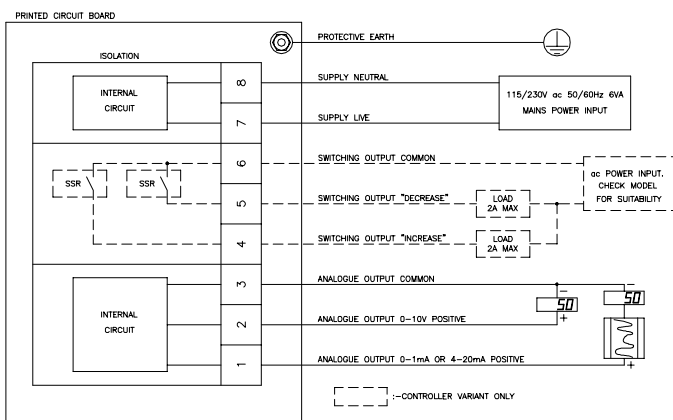

## OUTSTANDING FEATURES

**Solid State Circuitry** - no mechanical parts, providing high reliability, maintenance free.

**Robust VRP Transducer** - increased sensitivity ideal for flue gas draught measurement.

**Self Contained Transmitter/Controller** - reduced installation costs, no need for interface relays or contactors.

**Standard 4-20mA/0-10Vdc** - high accuracy and stability for re-transmission to recorder, logger or EMS.

**Solid State Control/Alarm Output** - direct switched output to control a.c. motor/actuator.

**Selectable filters** - for damping draught fluctuations.

**SKIL CONTROLS LIMITED**

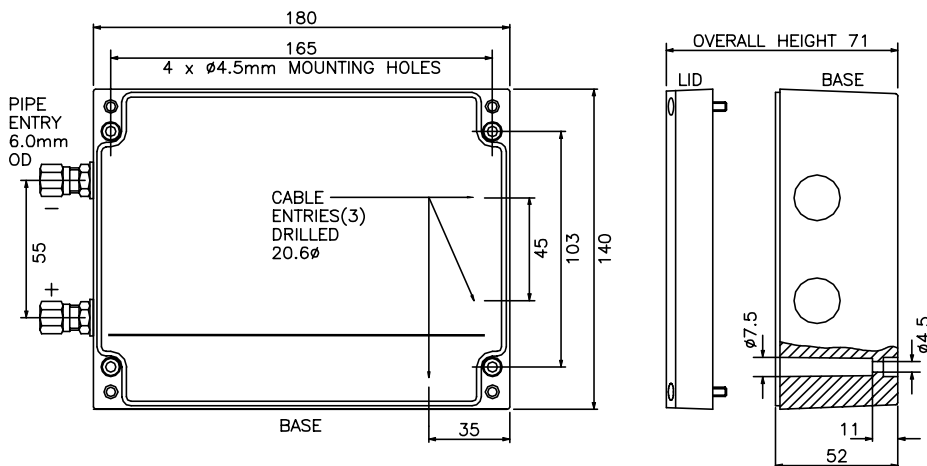

## SPECIFICATION

### Environmental

Enclosure : Diecast aluminium Al Si 12, DIN 1725.  
Weatherproof to IP 65 Wall mounting. Length 180, width 140, height 71, excluding fittings.

Pressure connection: 6mm OD compression fittings

Cable entries : 3 off drilled 20.6mm Dia. For M20 x 1.5 pitch or pq 13.5

Operating temperature : -18°C to 65°C

Weight : 1.5 kg net

### Electrical

Supply voltage: 115V or 230Vac  $\pm 10\%$  50/60 Hz

Analogue output current: 4-20mA or 0-1mA switch  
Selectable. Max insertion 600 ohms

Analogue output voltage: 0-10V dc. Max current 5.0 mA

Damping filter time constant: 0.5 to 5 seconds, switch selectable

### Control Board (where fitted)

Control switching output: Solid-state relays, 12-80Vac or 80-240Vac (see control options)  
2 ampere, resistive.

Damping filter time constant: 0.5 to 5 seconds, switch selectable.

Pressure Ranges: 5 to 1000 mm water gauge. Gauge or differential(0.5 mbar 100 mbar)

### Pressure Media

Typically air or similar non-conducting gases.

### Transducer

Capacitance principle with stainless steel body and diaphragm and electrode. Ceramic insulator. Internal temperature compensation.

### Performance

Accuracy<sup>1</sup>  $\pm 1.2\%$  of full-scale, at constant temperature

Non-linearity(BFSL)  $\pm 1\%$  of full-scale

Hysteresis 0.2% of full-scale

Non-repeatability 0.2% of full-scale

Maximum line pressure 10 PSI in positive or negative direction

### Thermal effects:

Zero/span shift 0.1% per °C

Compensated range -18 to +65°C

Warm up shift<sup>2</sup> 0.5% of full-scale total

## Ordering Information and Model Code

Key Model Code **222** **A** **1**

Table 1 - Range

Table 2 - Control Options

### KEY MODEL CODE

CODE	DESCRIPTION
222	Low Pressure Transmitter/Controller Supply: 230/115V (selectable) +10% - 15% 50/60 Hz Output: 0-10V dc standard with 0 to 1mA or 4 to 20mA selectable

### TABLE 1 - RANGE

CODE	DESCRIPTION $\pm$ Pressure or Differential Pressure
A	0-5mm W.G. (0 to 0.5 millibar)
B	0-10mm W.G. (0 to 1 millibar)
C	0-20mm W.G. (0 to 2 millibar)
D	0-40mm W.G. (0 to 4 millibar)
E	0-100mm W.G. (0 to 10 millibar)
F	0-200mm W.G. (0 to 20 millibar)
G	0-500mm WG (0 to 50 millibar)
H	0-1000mm WG (0 to 100 millibar)

### TABLE 2 - CONTROL OPTIONS

CODE	DESCRIPTION
1	Tri-state, solid state relay for control or high/low alarm (12 - 80V ac)
2	Tri-state, solid state relay for control or high/low alarm (80 - 240V ac)

<sup>1</sup>Accuracy expressed as the root sum squares of non-linearity, hysteresis and non-repeatability.

<sup>2</sup> While internal temperature compensation becomes effective



SKIL CONTROLS LIMITED  
GREENHEY PLACE  
SKELMERSDALE  
LANCASHIRE WN8 9SB  
UNITED KINGDOM

Telephone +44 (0) 1695 714600  
Fax: +44 (0) 1695 714611  
email: sales@skilcontrols.com



SKIL CONTROLS LIMITED  
GREENHEY PLACE  
SKELMERSDALE  
LANCASHIRE WN8 9SB  
UNITED KINGDOM

Telephone + 44 (0) 1695 714600  
Fax: +44 (0) 1695 714611  
e-mail: [enquiries@skilcontrols.com](mailto:enquiries@skilcontrols.com)

©SKIL CONTROLS LTD 15/08/97